

BOHRBUCHSE DIN 172, MIT BUND

Artikel-Nr.: B12.d₁.L₁



Werkstoff:

Einsatzstahl, gehärtet.
Härte: 740 ± 40 HV10

Ausführung:

Durchmesser d₁ und d₂ geschliffen.

Bestellbeispiel: d₁ = 8,2, L₁ = 20
B12.0820.020

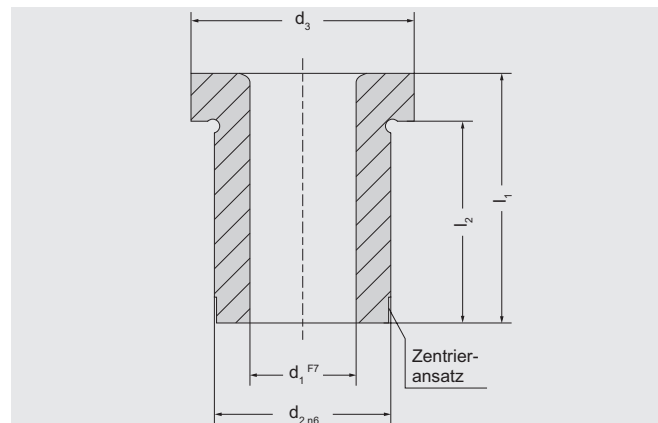

d ₁ *	d ₂	d ₃	kurz		mittel		lang	
			l ₁	l ₂	l ₁	l ₂	l ₁	l ₂
0,4 – 1,0	3	6	6	4	9	7	–	–
1,1 – 1,8	4	7	6	4	9	7	–	–
1,9 – 2,6	5	8	6	4	9	7	–	–
2,7 – 3,3	6	9	8	5,5	12	9,5	16	13,5
3,4 – 4,0	7	10	8	5,5	12	9,5	16	13,5
4,1 – 5,0	8	11	8	5,5	12	9,5	16	13,5
5,1 – 6,0	10	13	10	7	16	13	20	17
6,1 – 8,0	12	15	10	7	16	13	20	17
8,1 – 10,0	15	18	12	9	20	17	25	22
10,1 – 12,0	18	22	12	8	20	16	25	21
12,1 – 15,0	22	26	16	12	28	24	36	32
15,1 – 18,0	26	30	16	12	28	24	36	32
18,1 – 22,0	30	34	20	15	36	31	45	40
22,1 – 26,0	35	39	20	15	36	31	45	40
26,1 – 30,0	42	46	25	20	45	40	56	51
30,1 – 35,0	48	52	25	20	45	40	56	51
35,1 – 42,0	55	59	30	25	56	51	67	62
42,1 – 48,0	62	66	30	24	56	50	67	61
48,1 – 55,0	70	74	30	24	56	50	67	61
55,1 – 63,0	78	82	35	29	67	61	78	72

*Stufung d₁ = 0,1 mm